

# SABRE PHANTOM CELL BUSTER<sup>®</sup> - EVAPORATING DELIVERY

## The PHANTOM CELL BUSTER - MK-9 with extension wand - Technical Specifications

Height:	10.50"	26.70 cm
Diameter:	2.50"	6.50 cm
Weight:	16.0 ozs. / 448 gr. / 480 ml	
Warranty:	5 years	
Firing Mechanism:	Pistol Grip with Safety and wand extension	
Propellant:	HFC 134a	
Canister:	Seamless extruded aluminum – Rated 2Q	
Operating Temps:	0° F (-17° C) to 120° F (50° C)	

**Formulation:** Oil soluble Oleoresin Capsicum (OC) and ultraviolet marking dye. The formulation is **non-flammable** and electronic immobilization device compatible. Canisters contain an operating pressure of 100 PSI.

**Labeling:** All canisters are labeled with a protective Mylar over lamination cover which resists wear and water damage. Canisters are labeled with the shot pattern, batch number, serial number and expiration date. Individually serialized canisters permit easy identification and link to formulation batch numbers for quality assurance tracking.

**Quality Control:** Manufacturer maintains quality control system in accordance with the American National Standards Institute (ANSI) for the following:

Operation Test	Discharge Duration Test
Temperature Cycle Test	Operating Weight Test
One Year Time Leakage Test	Pressure Vessel Test
Hydrostatic Pressure Test	Gasket Dependability Test
Intermittent Discharge Test	High Temperature Exposure Test

**Federal Regulations:** The manufacturer certifies that all units comply with the following:

29 CFR 1910	Occupational Safety And Health Standards	AOAC 995.03
16 CFR 1500.41	Test for skin irritant	16 CFR 1500.130
16 CFR 1500.45	Test method for determining flammability of contents of self pressurized canisters	16 CFR 1500.42 16 CFR 1500.3

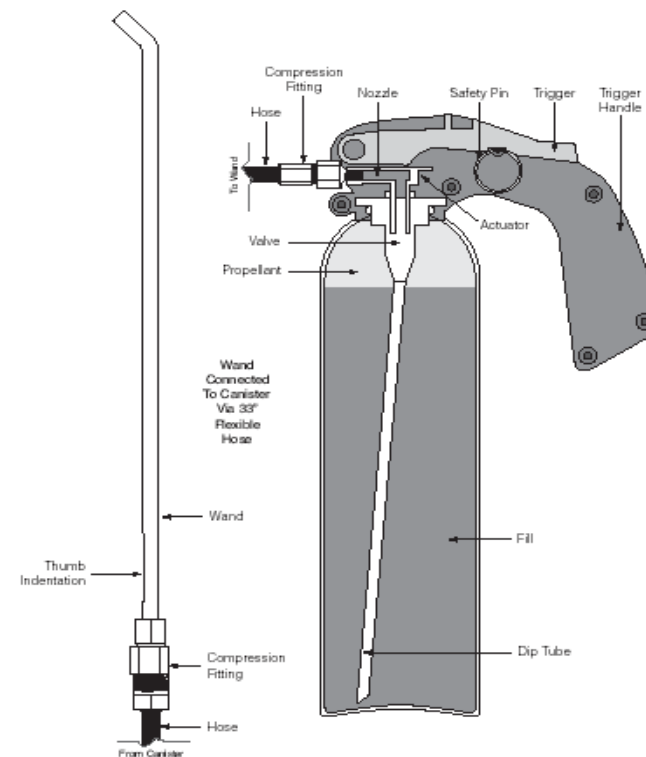

Oleoresin Capsicum Assay  
Labeling of self pressurized canisters  
Test for eye irritant  
Acute Inhalation Toxicity Study

	Training			Level III Formula		
	SABRE PHANTOM <sup>®</sup> Inert			SABRE Red PHANTOM <sup>®</sup>		
Model #	90PTM60-W	90PTM60-A	90PTM60-PWH	92PTM60-W	92PTM60-A	92PTM60-PWH
Description	Inert Cell Buster	Canister and Assembly, no hose or wand	Inert Cell Buster with PUNCTURE Wand	Cell Buster	Canister and Assembly, no hose or wand	Cell Buster with PUNCTURE Wand
Delivery	Evaporating Fog	Evaporating Fog	Evaporating Fog	Evaporating Fog	Evaporating Fog	Evaporating Fog
1-second bursts:	Approx 17	Approx 17	Approx 21	Approx 17	Approx 17	Approx 21
Time to Empty:	15 Seconds	15 Seconds	19 Seconds	15 Seconds	15 Seconds	19 Seconds
Range (Ft/Mtrs)	12-15/4-5	12-15/4-5	12-15/4-5	12-15/4-5	12-15/4-5	12-15/4-5
Active Ingrid	NA	NA	NA	10% OC	10% OC	10% OC
SHU's	NA	NA	NA	2,000,000	2,000,000	2,000,000
Scoville Content	NA	NA	NA	200,000	200,000	200,000
Capsaicinoids	NA	NA	NA	1.33%*	1.33%*	1.33%*

\* AOAC Official Method 995.03 Capsaicinoids in Capsicums and Their Extractives, Liquid Chromatographic Method (HPLC). Security Equipment Corporation uses AOAC Method 995.03 because it is the preferred method of the Environmental Protection Agency and the U.S. Federal Government.